

日标法兰参数系列

5Kg/Cm ² JIS B2220-1984(KSB 1503-1999).....002	30Kg/Cm ² WELDING NECK STEEL PIPE FLANGES.....010
10Kg/Cm ² JIS B2220-1984(KSB 1503-1999).....003	40Kg/Cm ² WELDING NECK STEEL PIPE FLANGES.....011
16Kg/Cm ² JIS B2220-1984(KSB 1503-1999).....004	63Kg/Cm ² WELDING NECK STEEL PIPE FLANGES.....012
20Kg/Cm ² JIS B2220-1984(KSB 1503-1999).....005	KSV 7815 JIS F 7805 1K.....013
30Kg/Cm ² JIS B2220-1984(KSB 1503-1999).....006	KSB 1511-1987 JIS B 2220-1977 2K.....014
40Kg/Cm ² JIS B2220-1984(KSB 1503-1999).....007	5K SET-ON FLANGE JIS B 2220-1999.....015
10Kg/Cm ² WELDING NECK STEEL PIPE FLANGES...008	10K SET-ON FLANGE JIS B 2220-1999.....016
20Kg/Cm ² WELDING NECK STEEL PIPE FLANGES...009	KS B2332-1994 & KS D 4308 KS B 2333-1995.....017

5Kg/Cm² JIS B2220-1984(KSB 1503-1999) 5Kg/Cm² SLIP-ON WELDING STEEL PIPE FLANGES

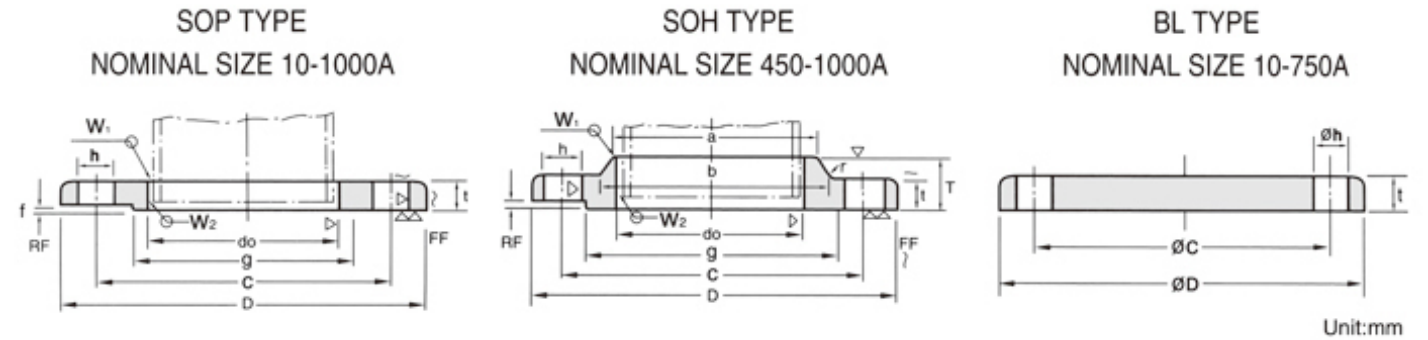

Nominal Bore of Flange	Outside Diam. of Applicable Pipe	Inside Diam. of Flange do	Outside Diam. of Flange D	Sectional Dimensions of Flange							Dia. of Bolt			Weight(kg)			
				t	T	Diam. of Hub		Rad -ius r	Raised face f	Diam. of Raised Face g	Diam. of Bolt Circle C	Number of Bolt Holes	Hole Diam h	Nominal Bolt Size	SOP	BL	SOH
						a	b										
(10)	17.3	17.8	75	9	-	-	-	-	1	39	55	4	12	M10	0.27	0.3	-
15	21.7	22.2	80	9	-	-	-	-	1	44	60	4	12	M10	0.30	0.4	-
(20)	27.2	27.7	85	10	-	-	-	-	1	49	65	4	12	M10	0.37	0.5	-
25	34.0	34.5	95	10	-	-	-	-	1	59	75	4	12	M10	0.45	0.6	-
(32)	42.7	43.2	115	12	-	-	-	-	2	70	90	4	15	M12	0.78	0.9	-
40	48.6	49.1	120	12	-	-	-	-	2	75	95	4	15	M12	0.83	1.0	-
50	60.5	61.1	130	14	-	-	-	-	2	85	105	4	15	M12	1.07	1.4	-
65	76.3	77.1	155	14	-	-	-	-	2	110	130	4	15	M12	1.49	2.0	-
80	89.1	90.0	180	14	-	-	-	-	2	121	145	4	19	M16	1.99	2.7	-
(90)	101.6	102.6	190	14	-	-	-	-	2	131	155	4	19	M16	2.09	3.0	-
100	114.3	115.4	200	16	-	-	-	-	2	141	165	8	19	M16	2.39	3.7	-
125	139.8	141.2	235	16	-	-	-	-	2	176	200	8	19	M16	3.23	5.2	-
150	165.2	166.6	265	18	-	-	-	-	2	206	230	8	19	M16	4.41	7.5	-
(175)	190.7	192.1	300	18	-	-	-	-	2	232	260	8	23	M20	5.51	9.5	-
200	216.3	218.0	320	20	-	-	-	-	2	252	280	8	23	M20	6.33	12.2	-
(225)	241.8	243.7	345	20	-	-	-	-	2	277	305	12	23	M20	6.64	14.0	-
250	267.4	269.5	385	22	-	-	-	-	2	317	345	12	23	M20	9.45	19.3	-
300	318.5	321.0	430	22	-	-	-	-	3	360	390	12	23	M20	10.3	24.3	-
350	355.6	358.1	480	24	-	-	-	-	3	403	435	12	25	M22	14.0	33.2	-
400	406.4	409.0	540	24	-	-	-	-	3	463	495	16	25	M22	16.9	41.9	-
450	457.2	460.0	605	24	40	495	500	5	3	523	555	16	25	M22	21.6	53.0	24.8
500	508.0	511.0	655	24	40	546	552	5	3	573	605	20	25	M22	23.1	61.9	26.9
550	558.8	562.0	720	26	42	597	603	5	3	630	665	20	27	M24	30.3	81.2	34.1
600	609.6	613.0	770	26	44	648	654	5	3	680	715	20	27	M24	32.7	93.2	37.5
650	660.4	664.0	825	26	48	702	708	5	3	735	770	24	27	M24	35.9	106.9	42.8
700	711.2	715.0	875	26	48	751	758	5	3	785	820	24	27	M24	38.2	120.6	45.4
750	762.0	766.0	945	28	52	802	810	5	3	840	880	24	33	M30	48.7	150.5	57.4
800	812.8	817.0	995	28	52	854	862	5	3	890	930	24	33	M30	51.2	167.4	60.8
(850)	863.6	868.0	1045	28	54	904	912	5	3	940	980	24	33	M30	54.4	185.1	63.5
900	914.4	919.0	1095	30	56	956	964	5	3	990	1030	24	33	M30	61.1	218.1	75.3
1000	1016.0	1021.0	1195	32	60	1058	1066	5	3	1090	1130	28	33	M30	70.5	277.3	88.5
*(1100)	1117.6	1123	1305	32	-	-	-	-	3	1200	1240	28	33	M30	81.7	331.9	-
*1200	1219.2	1225	1420	34	-	-	-	-	3	1305	1350	32	33	M30	102.0	417.8	-
*1350	1371.6	-	1575	34	-	-	-	-	3	1460	1505	32	33	M30	115.9	515.6	-
*1500	1524.0	-	1730	36	-	-	-	-	3	1615	1660	36	33	M30	157.4	659.2	-

1. Flanges of parenthesized nominal diameter had letter not be used.
2. The facing of flanges shall conform to KS B1509(JIS B2202)1984.
3. Nominal diameter over 1000 is manufacturer's standard(*).